

## OPERATION, INSTALLATION AND SERVICE MANUAL

### APPLICATION

The CM800/CM900 (CM-800, CM-900) Emergency Call Signaling System is designed for elderly housing, retirement facilities or wherever an Emergency Call System is required.

The Emergency Call System provides audible and visual indication of all calls originating in the system.

The CM800/CM900 Annunciator contains lamps for call indication, as well as a tone-off switch and audible tone signaling devices.

Calls can be activated by Emergency *pull station* models SF-117/2B, SF-117/2C, SF-117/4B, SF-117/4C, SF-118/2B, SF-118/2C, SF-118/4B, SF-118/4C or by *push button* models SF-154, SF-154B.

### FEATURES

- Choice of signaling stations
- Modular master annunciators in 4 or more zones
- Zones custom numbers using RP-021CM lens markings
- Choice of flush, surface or desk mount annunciator



SF-117/2B SF-117/4C  
Pull Stations



LI-381  
Dome Light



BE-005  
6" Vibrating Bell



PK-2019  
Annunciator Control



56 Zone CM-800  
Annunciator:  
1 CM-800/20  
1 AM-800/36  
56 RP-021CM  
1 OF-202T

# Table of Contents

---

<b>System Operating Instructions</b> .....	<b>1</b>
CM800, CM900 Annunciators .....	1
SF117, SF118 Emergency Call Stations .....	1
SF154 Emergency Call Station .....	1
IR019, IR019B Remote Annunciator Tone Speakers .....	2
LI381 Corridor Light .....	2
LI382 Corridor Light .....	2
LI118B, LI123B Corridor Lights .....	2
BE005, BE007 Corridor Bells .....	2
<b>System Installation</b> .....	<b>3</b>
Installation Procedure .....	3
Equipment Locations .....	3
Wiring Installation .....	3
Housing Installation .....	4
Wire Checkout .....	4
Connections Checkout .....	4
<b>Illustrations</b>	
Figure 1—Master Panel Housing Chart and Wall Cut-Out Details .....	5
Figure 2—Ring and Back Box for SF117, SF118 and SF154 Emergency Call Stations .....	5
Figure 3—Ring and Back Box for IR019 & IR019B Tone Speakers, and LI118B, LI123B, LI381 & LI382 Corridor Lights .....	5
Figure 4—Emergency Call Hook-Up Diagram with SF117/2, SF118/2 & SF154 Emergency Switches, and LI381 & LI118B Corridor Lights .....	6
Figure 5—Emergency Call Hook-Up Diagram with SF117/4 Continuous Duty Door Release, LI381 Corridor Light, LI123B Corridor Light with Buzzer, and BE005 Corridor Bell .....	7
Figure 6—Emergency Call Hook-Up Diagram with SF117/2 Continuous Duty Door Release, LI381 Corridor Light, Smoke Detector, and BE007 Corridor Bell .....	8
Figure 7—Connection Diagram for Parallel CM800 Panels .....	8

# System Operating Instructions

---

System operators must read the following operating instructions concerning system equipment and terms used in conjunction with the equipment.

## CM800 (CM-800), CM900 (CM-900) Annunciators

### *Answer Emergency Calls:*

Emergency calls are indicated by simultaneous operation of the following signals:

- Steady illumination of the associated station selector lamp, which is marked to indicate call origin.
- Rapidly pulsating audible tone. The audible call signal may be canceled by pressing the tone-off button. The tone-off light will illuminate to indicate that tone is silenced. The tone-off button may be pressed at any time to verify operation of the tone-off lamp.

Call signals may only be canceled at the point of origin, and all calls must be answered in person.

### *Test Station Annunciator Lamp (if so equipped):*

One lamp test button is provided on each panel of annunciator lamps. Press the lamp test button—all annunciator lamps on that panel should be illuminated.

### *Improper Operation:*

If the CM800 or CM900 Annunciator fails to operate as described, contact qualified maintenance personnel. If a malfunction occurs during a call-in, causing a lack of indication of call origin on the master station, first determine the origin of the call by observing which corridor light is illuminated, and then inform qualified personnel.

## SF117, SF118 Emergency Call Stations

### *Place an Emergency Call:*

Pull the call cord and wait for an Attendant. (**Note:** The SF118 station has a red call-placed light that illuminates when the cord is pulled.)

### *Reset the Station:*

Push the slide switch up.

### *Improper Operation:*

If the station does not operate as described, contact qualified personnel. There are no user serviceable parts on SF117 and SF118 Emergency Call Stations.

## SF154 (SF-154B) Emergency Call Station

### *Place an Emergency Call:*

Press the switch in so that the red area of the switch is visible, and wait for an Attendant.

### *Reset the Station:*

Press the switch out so that the red area of the switch is not visible.

### *Improper Operation:*

If the station does not operate as described, contact qualified personnel. There are no user serviceable parts on the SF154 Emergency Call Station.

### IR019 (IR-019), IR019B (IR-019B) Remote Annunciator Tone Speakers

***Emergency Calls:***

Emergency calls are indicated by a rapidly pulsating audible tone. The audible tone signal can be silenced by pressing the tone-off switch. (The IR019 is not equipped with a tone-off light.) The IR019 and IR019B tone mimics the annunciator tone—either steady or pulsing.

***Improper Operation:***

If the speaker does not operate as described, contact qualified personnel. There are no user serviceable parts on the IR019 and IR019B Remote Annunciator Tone Speakers.

### LI381 (LI-381) Corridor Light

***Emergency Calls:***

Emergency calls are indicated by steady illumination of the corridor light associated with the calling station.

***Improper Operation:***

If the corridor light does not operate as described, contact qualified service personnel. There are no user serviceable parts on the LI381 Corridor Light, other than bulbs.

### LI382 (LI-382) Corridor Light

***Emergency Calls:***

Emergency calls are indicated by steady illumination of the corridor light associated with the calling station. The second light can be used for other call types initiated from the same zone.

***Improper Operation:***

If the corridor light does not operate as described, contact qualified service personnel. There are no user serviceable parts on the LI382 Corridor Light, other than bulbs.

### LI118B (LI-118B), LI123B (LI-123B) Corridor Lights

***Emergency Calls:***

Emergency calls are indicated by steady illumination of the corridor light and a steady buzzer.

***Improper Operation:***

If the corridor light does not operate as described, contact qualified service personnel. There are no user serviceable parts on the LI118 and LI123B Corridor Lights, other than bulbs.

### BE005 (BE-007), BE007 (BE-007) Corridor Bells

***Emergency Calls:***

Emergency calls are indicated by a steady ringing of the corridor bells.

***Improper Operation:***

If the corridor bell does not operate as described, contact qualified service personnel. There are no user serviceable parts on the BE005 and BE007 Corridor Bells.

# System Installation

---

## Installation Procedure

- Read the following instructions concerning system equipment, and determine installation methods before proceeding.
- Determine equipment locations.
- Install wiring.
- Install housings.
- Check wires.
- Connect equipment.
- Check connections.
- Apply power.
- Check system operation.

## Equipment Locations

### ***CM800, CM900 Annunciator:***

Locate CM800 and CM900 Annunciators within easy reach of operating personnel. Permitted operating temperature of 10°C–30°C must not be exceeded.

### ***SF117, SF118, SF154 Emergency Call Stations:***

Locate emergency stations where convenient for operation. Avoid areas where direct contact with water may occur. The SF117 and SF118 include a 6' long pull cord, permitting installation high enough to provide easy operation by the staff and by seated or prone patients. The SF154 is operated by means of a push button located on the station.

### ***IR019, IR019B Remote Annunciator Tone Speakers:***

Locate annunciator tone speakers as needed and where convenient for operation. Location must provide for unobstructed visibility of the tone-off indicator (IR019B).

### ***LI381, LI382, LI118B, LI123B Corridor Lights:***

Locate corridor lights in the corridor above or beside the door of the associated rooms. Location must provide unobstructed visibility of the corridor light in both directions.

### ***PK2019 (PK-2019) Control Unit:***

The PK2019 may be surface mounted adjacent to the SS106, if necessary. If remotely located, cable run from PK2019 to CM800/CM900 must not exceed 100'.

### ***PK601A (PK-601A) Power Supply:***

Surface mount the PK601A adjacent to the SS106 and PK2019.

### ***PK612A (PK-612A) DC Flasher:***

Surface mount the PK612A adjacent to the SS106 and PK2019.

### ***BE005/BE007 (BE-005/BE-007) Corridor Bells:***

Locate BE005 and BE007 Corridor Bells in corridor above door height. Location in corridor will be determined by the number of bells required on each floor.

### ***SS106 (AKA PS-30A) Transformer:***

Locate SS106 in an accessible area near a source of 117 VAC. Observe local codes.

## Wiring Installation

Run wiring conduit from corridor light to corridor light and terminate at the CM800 or CM900 annunciator panel. Select conduit size according to the application, as shown in wiring diagrams in this booklet. Observe local codes.

### ***PK2019 (PK-2019) Options:***

- For 30-second delay before tone, connect terminal A to terminal N.
- For steady tone, connect terminal W to terminal N. If the annunciator lamp is flashing, the tone will be intermittent despite terminal W connection.

## Housing Installation

### ***CM800, CM900 Annunciators:***

Flush Wall Mount—Provide a wall cutout as shown in *Figure 1*. Fit the back box and frame assembly into the prepared opening. Fasten the assembly in place. **Note:** The back box must be TekTone® OH200 Series.

Surface Wall Mount—Fasten the back box and frame assembly to the wall through the holes provided in back of the box, using suitable fasteners. **Note:** Back box must be TekTone® OH300 Series.

### ***SF117, SF118, SF154 Emergency Call Stations:***

Install single gang ring (or single gang ring and double gang box) as shown in *Figure 2* for each emergency call station in system. Minimum dimensions of back box must not be less than 4"×4"×1.5". Minimum opening on ring must not be less than 1.75"×2.75". Minimum clearance from live parts of the station to dead metal parts must not be less than 0.5".

### ***IR019, IR019B Remote Annunciator Tone Speakers:***

Install double gang ring (or double gang ring and double gang box) as shown in *Figure 3* for each tone speaker station. Minimum dimensions of back box must not be less than 4"×4"×1.5".

### ***LI118B, LI123B Corridor Lights:***

Install double gang ring (or double gang ring and double gang box) as shown in *Figure 3* for each tone speaker station. Minimum dimensions of back box must not be less than 4"×4"×1.75".

### ***LI381 (LI-381), LI382 (LI-382) Corridor Lights:***

Install double gang ring (or double gang ring and double gang box) as shown in *Figure 3* for each corridor light. Minimum dimensions of back box must not be less than 4"×4"×1.5". Minimum opening on ring must not be less than 2.75"×2.75". Minimum clearance from live parts of the station to dead metal parts must not be less than 0.5".

### ***BE005, BE007 Corridor Bells:***

Install a standard 4" Bell Box.

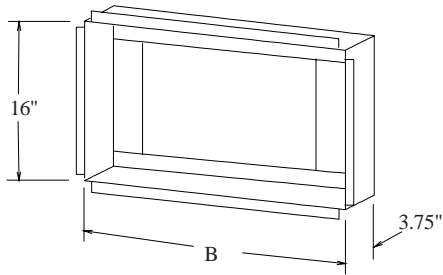
## Wire Checkout

Use an ohmmeter or other continuity checking device to test wires for shorts or grounds. If shorts or grounds are encountered, find and correct the problems before continuing. Make sure the minimum number of conductors that are needed for all of the equipment being used in the system are available.

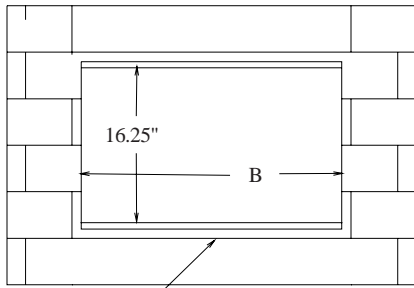
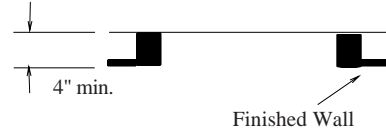
## Connections Checkout

Re-check all connections to equipment. If all wires and connections are satisfactory, connect the primary coil of the SS106 Transformer to a source of 117 VAC 60 Hz (30 VA max.).

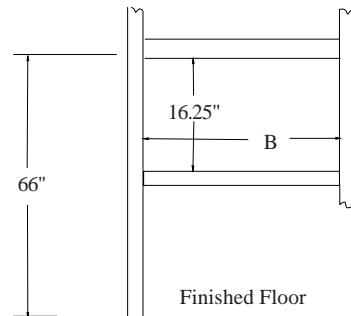
**Figure 1—Master Panel Housing Chart and Wall Cut-Out Details**



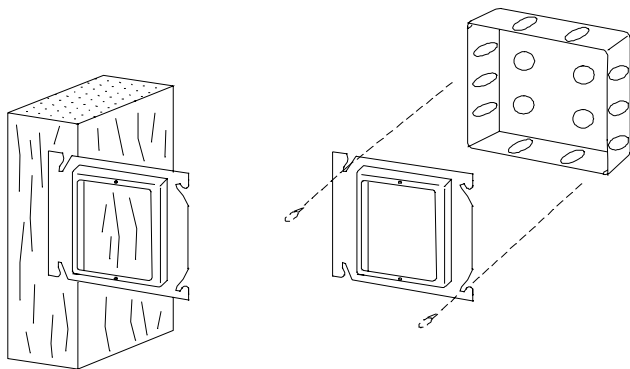
<i>Housing</i>		<i>Wall Opening</i>	
<b>Flush</b>	<b>Surface</b>	<b>Width (B)</b>	<b>Height</b>
OH202	OH302	8.5"	16.25"
OH203	OH303	12.5"	16.25"
OH204	OH304	16.5"	16.25"
OH205	OH305	20.5"	16.25"



In masonry walls, install 0.5"×4" wood fillers at top and bottom of opening for housing attachment.

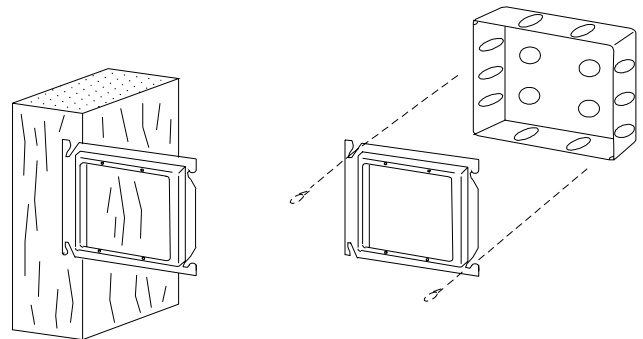


**Figure 2—Ring and Back Box for SF117, SF118 and SF154 Emergency Call Stations**



Install ring with panel mounting holes at top and bottom, as shown.

**Figure 3—Ring and Back Box for IR019 & IR019B Tone Speakers, and LI118B, LI123B, LI381 & LI382 Corridor Lights**

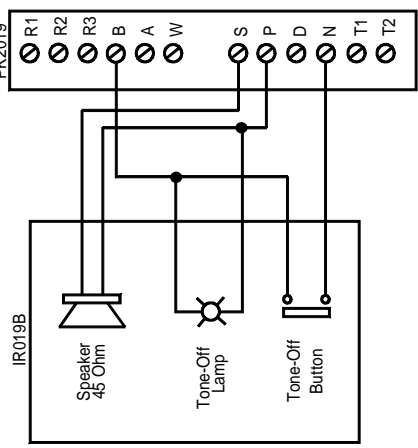


IL514 2g-ring 2g-box Rev0 123102 1

Install ring with panel mounting holes at top and bottom, as shown.

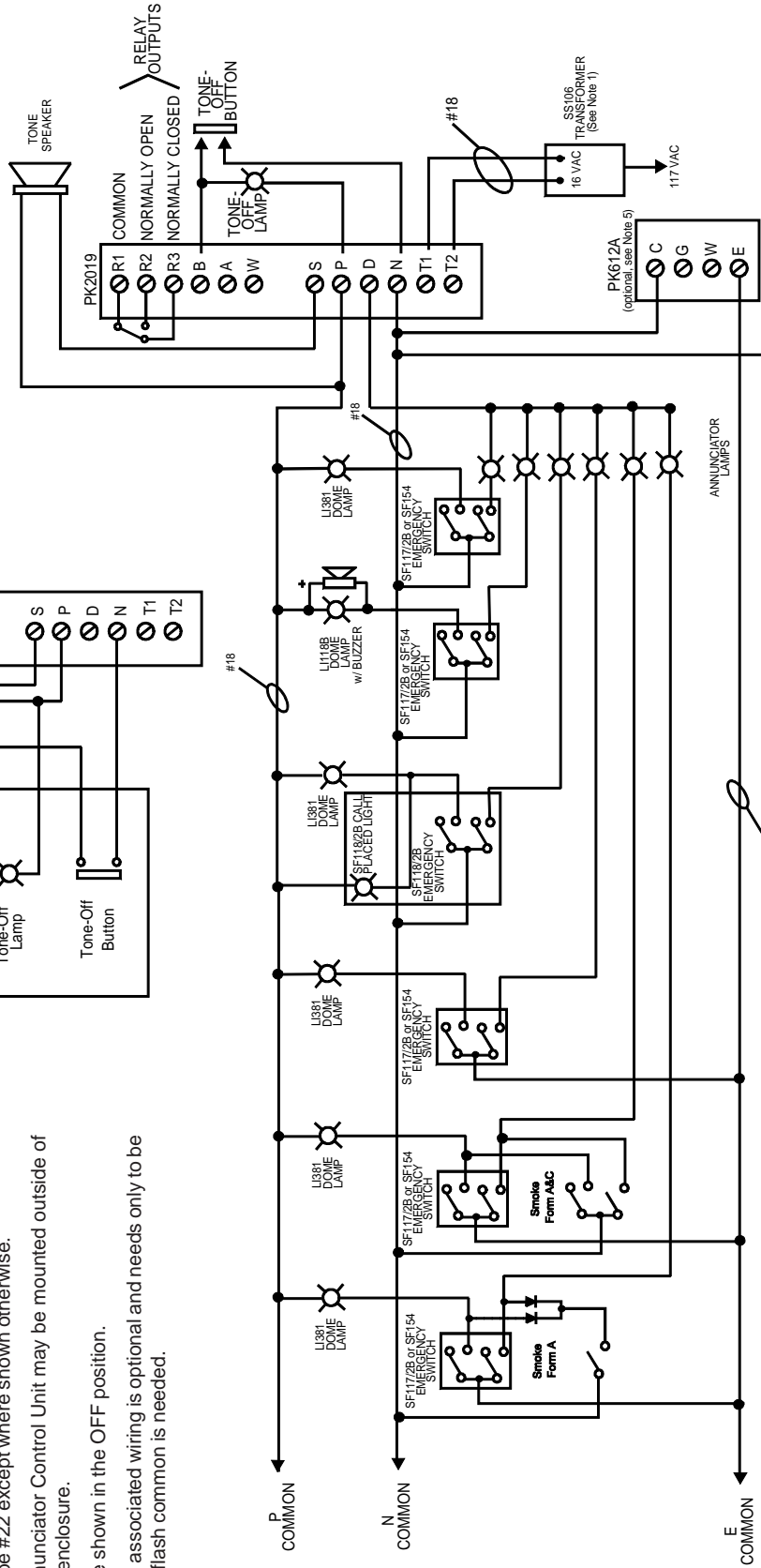
**Figure 4—Emergency Call Hook-Up Diagram with SF117/2, SF118/2 & SF154 Emergency Switches, and LI381 & LI118B Corridor Lights**

**Wiring Diagram for IR019, IR019B and PK2019**  
(Disregard wiring for tone-off lamp if wiring IR019.)



**Notes:**

1. Use 16 VAC connections on SS106 Transformer.
2. Wiring may be #22 except where shown otherwise.
3. PK2019 Annunciator Control Unit may be mounted outside of annunciator enclosure.
4. Switches are shown in the OFF position.
5. PK612A and associated wiring is optional and needs only to be installed if a flash common is needed.



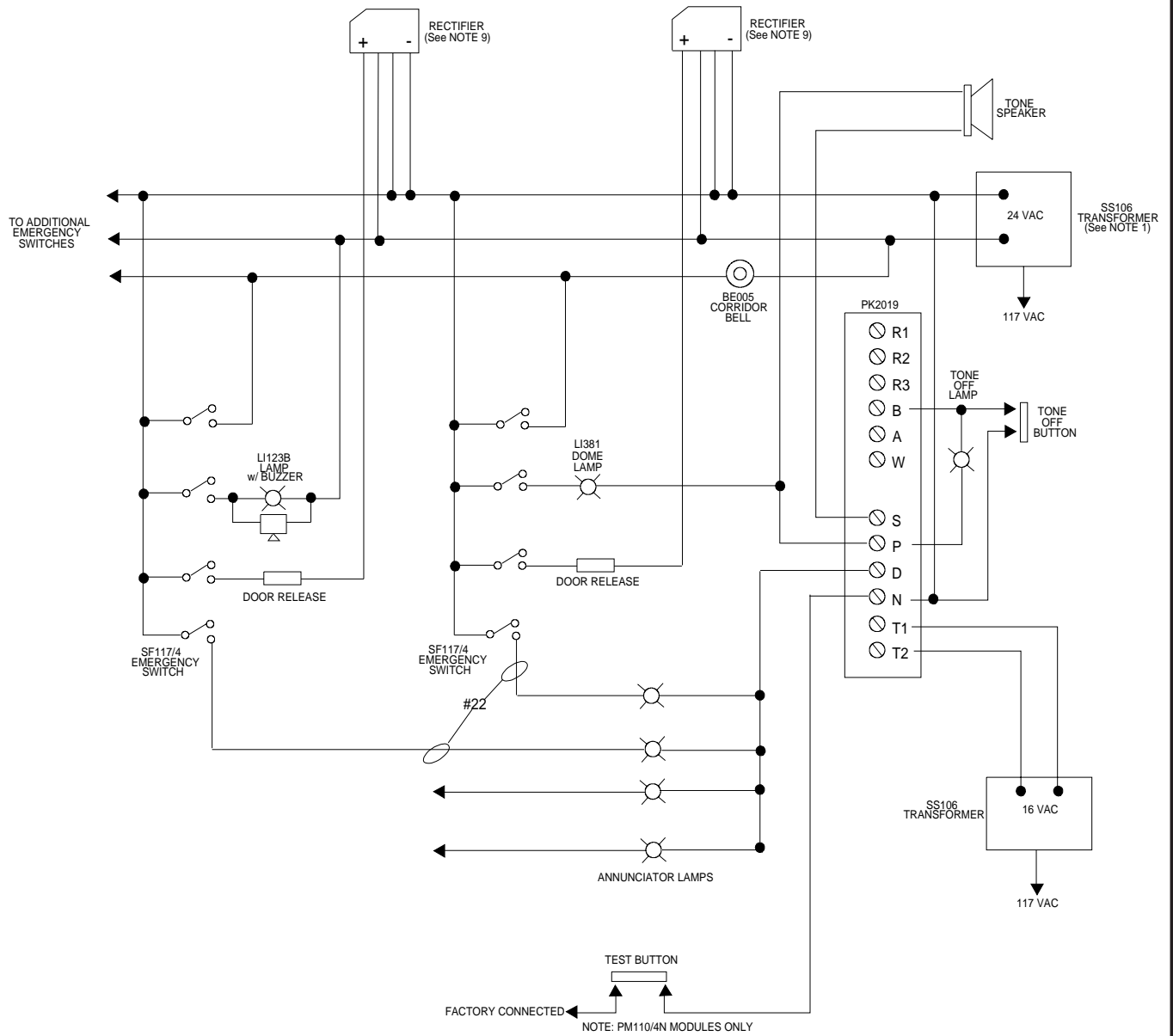
IL514 General Wiring Figure 4 Rev0 082702.1

#18 (optional, see Note 5)

FACTORY CONNECTED  
TEST BUTTON  
NOTE: PM1104N Modules only!



**Figure 5—Emergency Call Hook-Up Diagram with SF117/4 Continuous Duty Door Release, LI123B Corridor Light, LI123B Corridor Light with Buzzer, and BE005 Corridor Bell**



**IL514 General Wiring Figure 5 Rev0 123102 1**

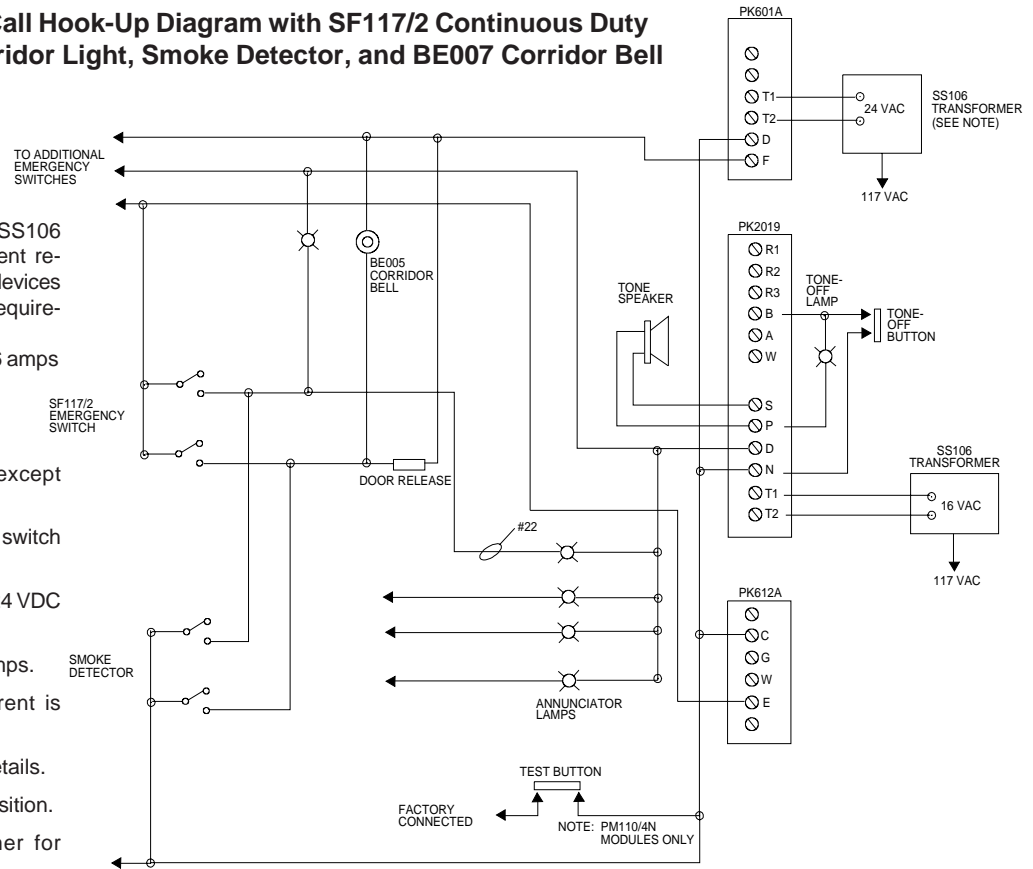
**Notes:**

1. Use 24 VAC connections on SS106 transformer. To calculate current requirements, add currents of all devices on at the same time. Current requirements are as follows:  
 Corridor Lamp with buzzer— .16 amps  
 Corridor Bell— .2 amps  
 Door release— .3 amps  
 Annunciator lamp— .04 amps
2. Wiring must be #18 gauge except where shown otherwise.
3. BE005 connects to emergency switch on the same floor only.
4. Door release (if used) must be 24 VDC continuous duty type.
5. Switch current capacity is 3 amps.
6. Power supply maximum current is 1 amp.
7. See *Figure 4* for additional wiring details.
8. Switches shown in the OFF position.
9. Rectifier RUFO® Model 1005 is not available from TekTone®.

**Figure 6—Emergency Call Hook-Up Diagram with SF117/2 Continuous Duty Door Release, LI381 Corridor Light, Smoke Detector, and BE007 Corridor Bell**

**Notes:**

1. Use 24 VAC connections on SS106 transformer. To calculate current requirements, add currents of all devices on at the same time. Current requirements are as follows:  
 Corridor Lamp with buzzer— .16 amps  
 Corridor Bell— .2 amps  
 Door release— .3 amps  
 Annunciator lamp— .04 amps
2. Wiring must be #18 gauge except where shown otherwise.
3. BE007 connects to emergency switch on the same floor only.
4. Door release (if used) must be 24 VDC continuous duty type.
5. Switch current capacity is 3 amps.
6. Power supply maximum current is 1 amp.
7. See Figure 4 for more wiring details.
8. Switches shown in the OFF position.
9. Do not use same transformer for PK2019 and PK601A.

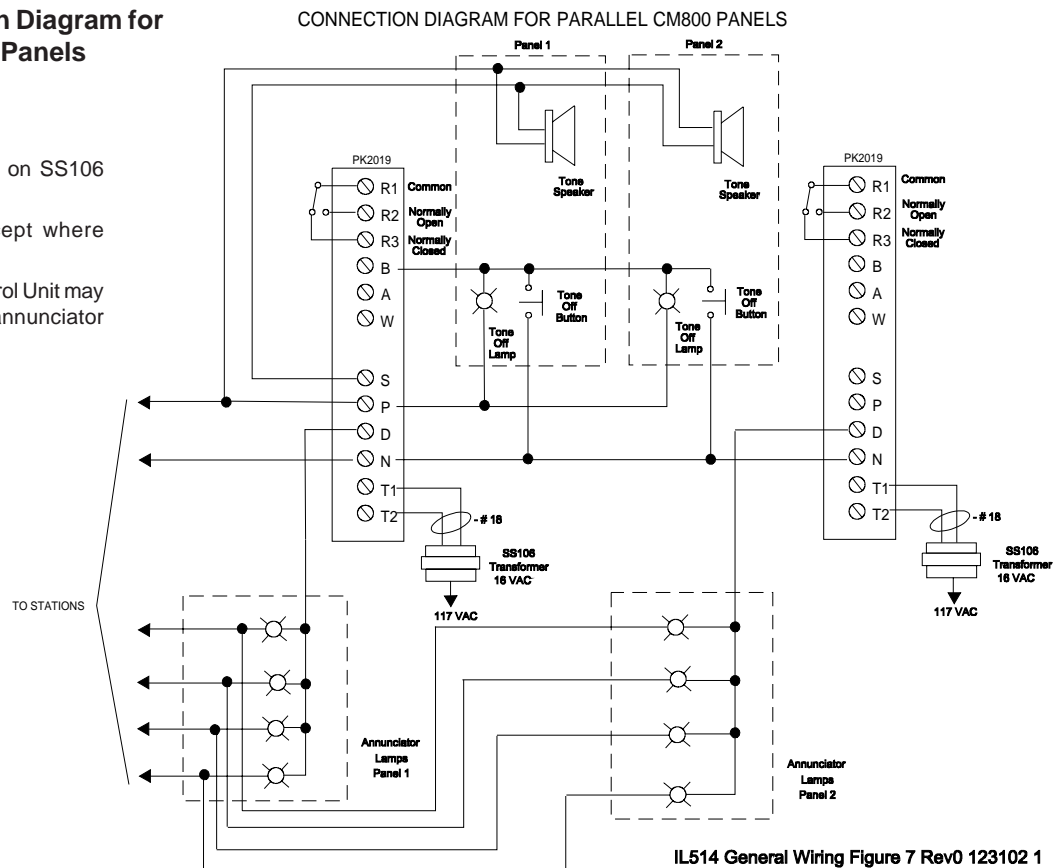


IL514 General Wiring Figure 6 Rev0 123102 1

**Figure 7—Connection Diagram for Parallel CM800 Panels**

**Notes:**

1. Use 16 VAC connections on SS106 Transformer.
2. Wiring may be #22 except where shown otherwise.
3. PK2019 Annunciator Control Unit may be mounted outside of annunciator enclosure.



IL514 General Wiring Figure 7 Rev0 123102 1