

Single-Channel Loop Detector

This “Self-tuning” loop detector is designed to be used with DoorKing vehicular gate operators **ONLY** and control an individual loop (including 2 series wired reversing loops configuration). The loop detector plugs into loop detector ports on the gate operator control board. This “Self-tuning” detector will constantly monitor the loop’s frequency status and “Self-tune” for any minor deviations with the frequencies to keep the loop operating normally and decrease “false calls”. The detector also employs several automatic and advanced features that will assist technicians in the field with trouble shooting loop problems. Refer to the **Loop Information Manual** located at www.dkaccess.com for information on installing in-ground loops.

Frequency DIP-Switches

When the detector is powered up, or when the reset button is pressed, the detector will blink out the frequency that the loop has tuned to (in KHz) on the L1 LED. For example, L1 blinks five times - pause - blinks six times indicates that the Loop has tuned to 56 KHz. This automatic frequency measurement is useful in applications for two or more loops that are in close proximity to each other.

DIP SW 2	Switch 1	Switch 2
High	OFF	OFF
Med-High	OFF	ON
Med-Low	ON	OFF
Low	ON	ON

A common problem with loops are when they are positioned too close to each other and their detection fields overlap. If the loops are on similar frequencies, this can cause “cross-talk” between the loops and “false calls” can occur in the loop detectors. Knowing what frequency each loop has tuned to allows you to adjust the frequencies of each

loop. Keep the frequencies as far apart from each other as possible and the loop with the longest length of wire should be set to the lowest frequency. Switching the frequency of a loop **WILL NOT** affect any of the operation adjustments or the over all detecting height of the loop.

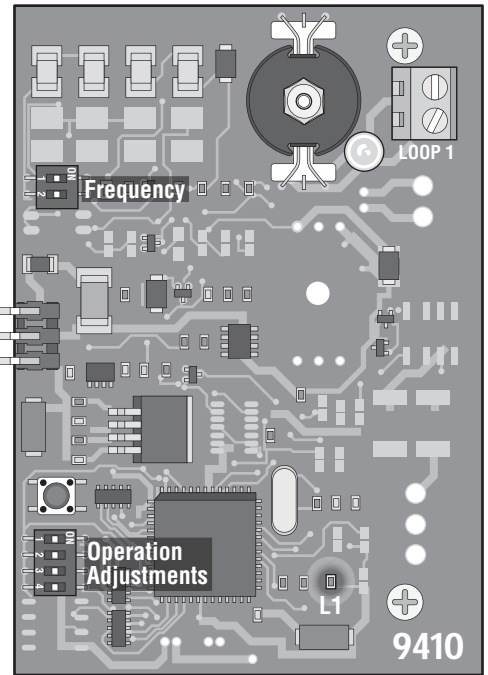

Operation Adjustments DIP-Switches

Turn On Fast-Trak Switch 1	DIP SW 1	Adjust Loop Sensitivity		Turn On Sensitivity Boost Switch 4
		Switch 2	Switch 3	
Normal-OFF Fast-Trak-ON	Low	OFF	OFF	Normal-OFF Boost-ON
	Med-Low	OFF	ON	
	Med-High	ON	OFF	
	High	ON	ON	

Loop Sensitivity

Adjusts how much moving metal must be present in the loop detection field before the loop detector will send an output.

Sensitivity Boost

Once the detector senses a vehicle, this feature increases the loop detector’s sensitivity to compensate for a higher section of that vehicle (usually a truck trailer or truck bed) that the detector may not completely sense, and allow the vehicle to pass completely over the loop before closing the gate. This prevents the loop detector from “losing detection” on a higher part of a vehicle and start the closing cycle before the vehicle has cleared the loop. This feature can be individually turned **ON** for each loop but **WILL NOT** increase a loop’s over all detecting height.

Fast-Trak

Fast-Trak is useful on a degraded loop that may drift in frequency over a period of time. An indication of this would be when the detector has an excessive amount of “false calls”. This is usually caused by poor quality wire in the loop itself, a poor wire connection in the loop system or wire insulation damage. It usually fails when the loop gets wet but will work OK when the moisture is gone. When Fast-Trak is turned ON, it will allow the loop’s frequency to drift more than normal and not give the excessive “false calls”. **Caution** should be exercised when using the Fast-Trak feature. If excessive frequency drift continues (indicated by an excessive amount of “false calls” with Fast-Trak turned ON), the loop itself will have to be replaced.

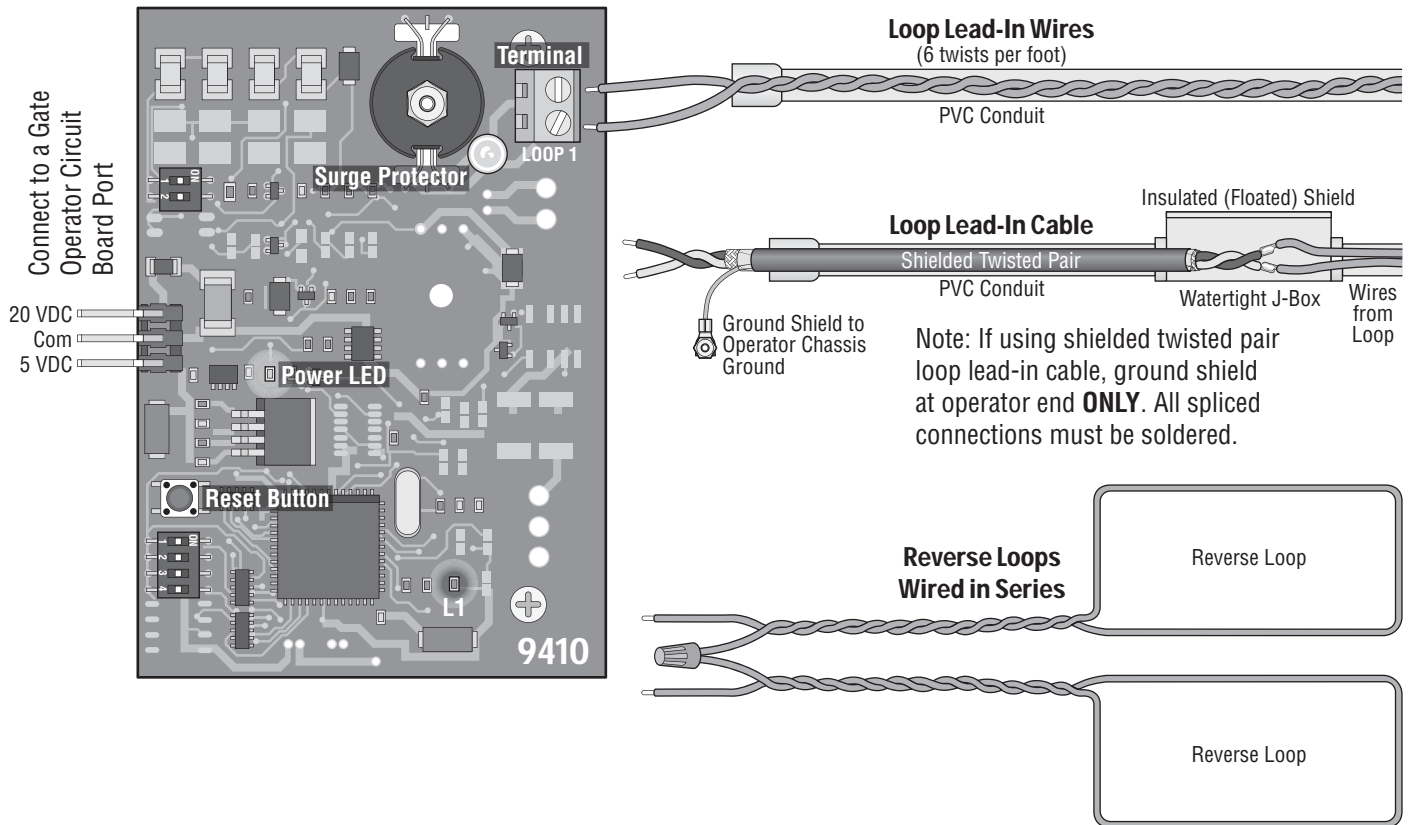

Loop 1 Terminal

Connect the loop lead-in wires or cable to terminal. Ground loop lead-in cable to operator chassis ground if used.

Reset Button

Pressing the reset button clears faults and resets the detector.

Power LED

Illuminates when detector has acceptable power.

L1 LED

Illuminates when loop detector senses a vehicle in the Loop’s detection field. It will also indicate the Loop’s frequency when the detector is powered up or when a physical problem exists in the loop itself.

Loop Monitoring with L1 LED

The loop detector constantly monitors the frequency of the loop to determine if the frequency is too high or too low, or if the loop system has a physical problem. When this happens, the detector will “Lock On” and the L1 LED will steadily flash when the loop has a problem. If the frequency of the loop returns to nominal levels, the detector will resume normal operation but L1 LED will continue to flash. A steadily flashing L1 LED is an indication that a physical problem exist in the loop system itself and that the loop will probably have to be replaced. The L1 LED can be reset by pressing the reset button.

