

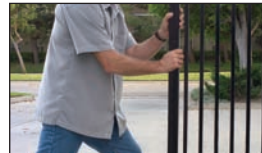

9100 VEHICULAR SLIDE GATE OPERATOR



entrapment
prevention system
reverses gate on contact



fail-safe release
Never be locked out (or in)
of your property



built in
power and reset switches

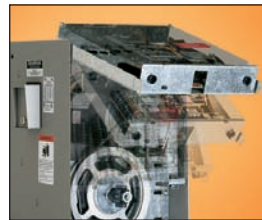

unique design
allows easy access to all
mechanical parts

- Electronic magnetic limits eliminate old style mechanical switches that can wear out, break or fail
- Automatic self-setting limits mean no limit switch adjustments – ever
- Safety – built-in mechanical and electronic reverse system
- Advanced microprocessor control board features programming switches to set the mode of operation required and has ports for DKS plug-in loop detectors to simplify wiring
- Convenience outlets for accessory transformers
- G90 galvanized steel frame prevents rusting
- This operator meets or exceeds the requirements of the UL 325 and UL 991 safety standards and is ETL Listed
- 5-year limited warranty

FEATURES

ACCESS CONTROL SOLUTIONS





9100 VEHICULAR SLIDE GATE OPERATORS

The DKS 9100 operator offers convenience, reliability and safe operation in a small, compact design meant to operate vehicular sliding gates in residential and commercial applications. The innovative fail-safe design of this operator significantly reduces the chance of injury or entrapment and makes it the safest slide gate operator on the market today! Designed with versatility in mind, the operator can be configured for front, center or rear drive applications and can be pad or post mounted.

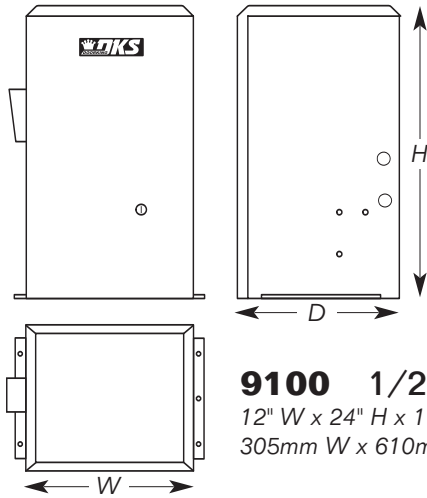

9100 1/2 HP
12" W x 24" H x 11.5" D
305mm W x 610mm H x 292mm D

9100 Specs

Class of operation	Max Gate Length *	Max Gate Weight *	HP	Power
I, II, III, IV	30 Ft 9.1 m	1000 Lbs. 453.5 kg	1/2HP continuous duty	115 VAC, 60 Hz, 5.4A

*Assumes gate to be in good condition and must be on a level surface

General Specs

Mechanical

Primary Reduction: Single cog belt
Chain: #41
Speed: Approximately 10 in/sec (254 mm/sec)
Cover: Steel cover is plated and painted
Frame: G90 Galvanized steel to prevent rusting

Manual Release

Fail Safe: Push gate open
Fail Secure: Keyed release optional

Operator kit

includes chain brackets, hardware, and 20-feet (6 m) of #41 chain

Advanced Features

Automatic limit adjustment
Auto-close timer 1-23 sec
Selectable stop / reverse loop function
Built in On / Off switch
Built in alarm reset switch
Programming switches allow you to set desired mode of operation
Partial-open and anti-tailgating features
Two 115 VAC convenience outlets for accessory transformers
Automatically assumes fail-safe mode when an entrapment condition exists
Ports for plug-in open and reverse loop detectors. DKS plug-in detectors only

Options Available

#40 chain.
Nickel plated chain.
Stainless steel chain.
Plug-in loop detectors.
Heater kit for cold environments.
Base plate to post mount (posts not included)
Fail-secure keyed release

Safety Standards

Complies with the UL 325 and UL 991 safety standards
ETL listed

Operating Temp

10°F to 140°F
12°C to 62°C
Heater kit recommended for colder environments

Shipping Weight

Approximately 125-185 lbs (65.7-83.9 kg)

Warranty

5-year limited factory warranty

DOORKING®, INC.

© 2006 All Rights Reserved. Product specifications may change without notice. Rev. 4/06

MEMBER:



Distributed by:

LEE DAN COMMUNICATIONS, INC.
www.leadan.com
info@leadan.com
Toll-Free: 800-231-1414